

RESISTIVE CIRCUITS

- KIRCHHOFF'S LAWS - THE FUNDAMENTAL CIRCUIT CONSERVATION LAWS- KIRCHHOFF CURRENT (KCL) AND KIRCHHOFF VOLTAGE (KVL)

KIRCHHOFF CURRENT LAW

ONE OF THE FUNDAMENTAL CONSERVATION PRINCIPLES
IN ELECTRICAL ENGINEERING

"CHARGE CANNOT BE CREATED NOR DESTROYED"

NODES, BRANCHES, LOOPS

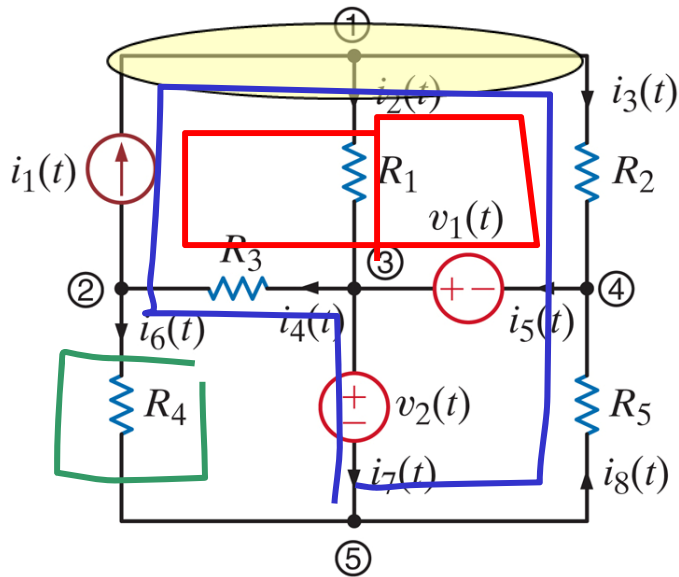

A NODE CONNECTS SEVERAL COMPONENTS.
BUT IT DOES NOT HOLD ANY CHARGE.

TOTAL CURRENT FLOWING INTO THE NODE
MUST BE EQUAL TO TOTAL CURRENT OUT
OF THE NODE

(A CONSERVATION OF CHARGE PRINCIPLE)

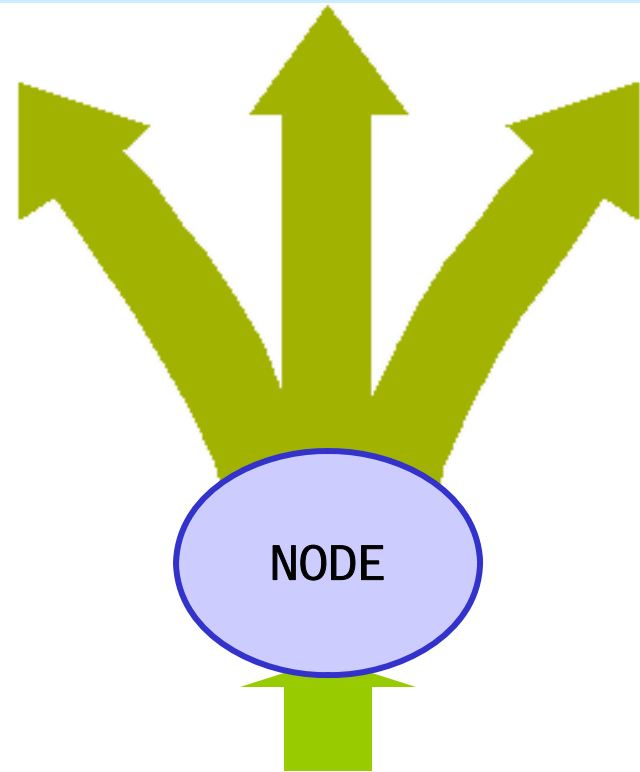

NODE: point where two, or more, elements are joined (e.g., big node 1)

LOOP: A closed path that never goes twice over a node (e.g., the blue line)

The red path is NOT a loop

BRANCH: Component connected between two nodes (e.g., component R_4)

KIRCHHOFF CURRENT LAW (KCL)

SUM OF CURRENTS FLOWING INTO A NODE IS EQUAL TO SUM OF CURRENTS FLOWING OUT OF THE NODE

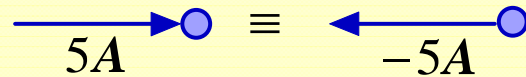

A current flowing into a node is equivalent to the negative flowing out of the node

ALGEBRAIC SUM OF CURRENT (FLOWING) OUT OF A NODE IS ZERO

ALGEBRAIC SUM OF CURRENTS FLOWING INTO A NODE IS ZERO

Write the KCL equation for the following node:

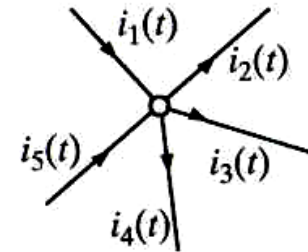

$$i_1(t) - i_2(t) - i_3(t) - i_4(t) + i_5(t) = 0$$

A node is a point of connection of two or more circuit elements. It may be stretched out or compressed for visual purposes.. But it is still a node

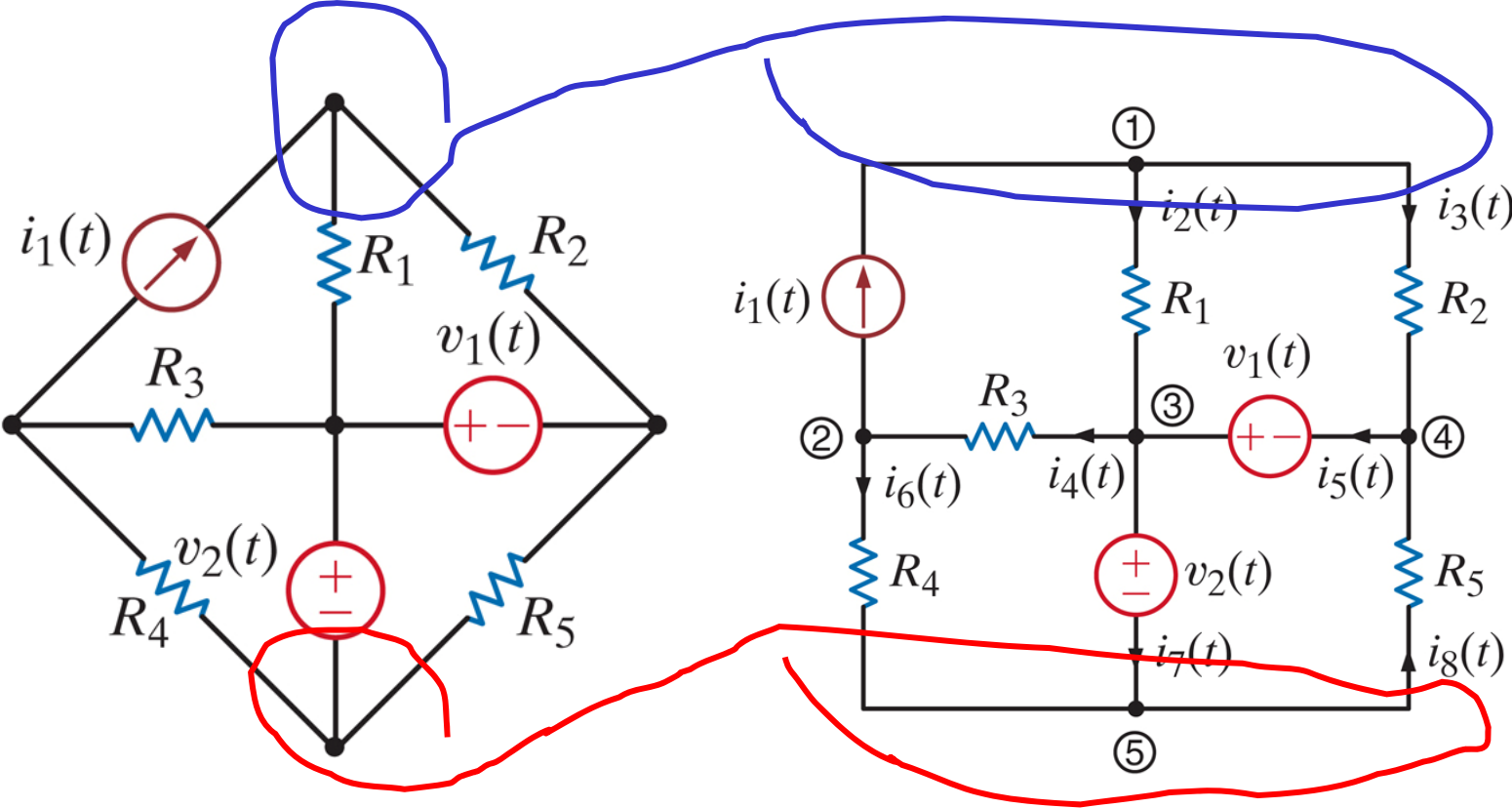

A GENERALIZED NODE IS ANY PART OF A CIRCUIT WHERE THERE IS NO ACCUMULATION OF CHARGE

... OR WE CAN MAKE SUPERNODES BY AGGREGATING NODES

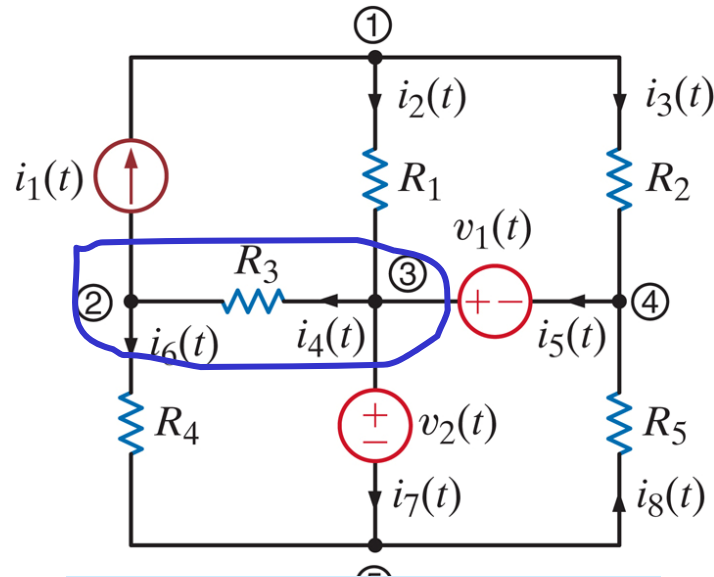

$$\text{Leaving 2: } i_1 + i_6 - i_4 = 0$$

$$\text{Leaving 3: } -i_2 + i_4 - i_5 + i_7 = 0$$

$$\text{Adding 2 \& 3: } i_1 - i_2 - i_5 + i_6 + i_7 = 0$$

INTERPRETATION: SUM OF CURRENTS LEAVING NODES 2&3 IS ZERO

VISUALIZATION: WE CAN ENCLOSE NODES 2&3 INSIDE A SURFACE THAT IS VIEWED AS A GENERALIZED NODE (OR SUPERNODE)

PROBLEM SOLVING HINT: KCL CAN BE USED TO FIND A MISSING CURRENT

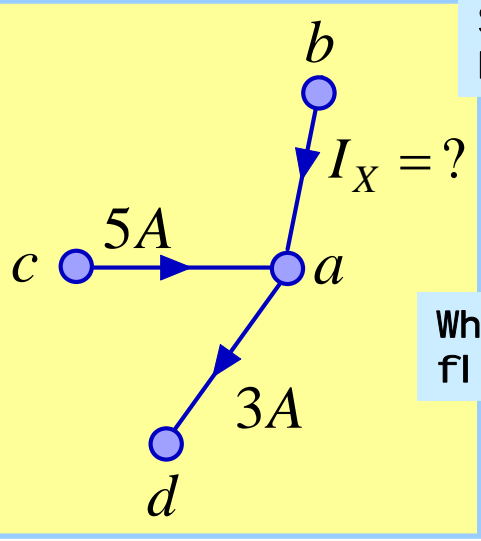

SUM OF CURRENTS INTO NODE IS ZERO

$$5A + I_X + (-3A) = 0$$

$$I_X = -2A$$

Which way are charges flowing on branch a-b?

... AND PRACTICE NOTATION CONVENTION AT THE SAME TIME...

$$I_{ab} = 2A,$$

$$I_{cb} = -3A$$

$$I_{bd} = 4A$$

$$I_{be} = ?$$

NODES: *a, b, c, d, e*
 BRANCHES: *a-b, c-b, d-b, e-b*

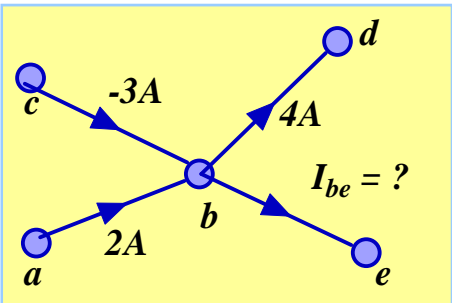

$$I_{be} + 4A + [-(-3A)] + (-2A) = 0$$

WRITE ALL KCL EQUATIONS

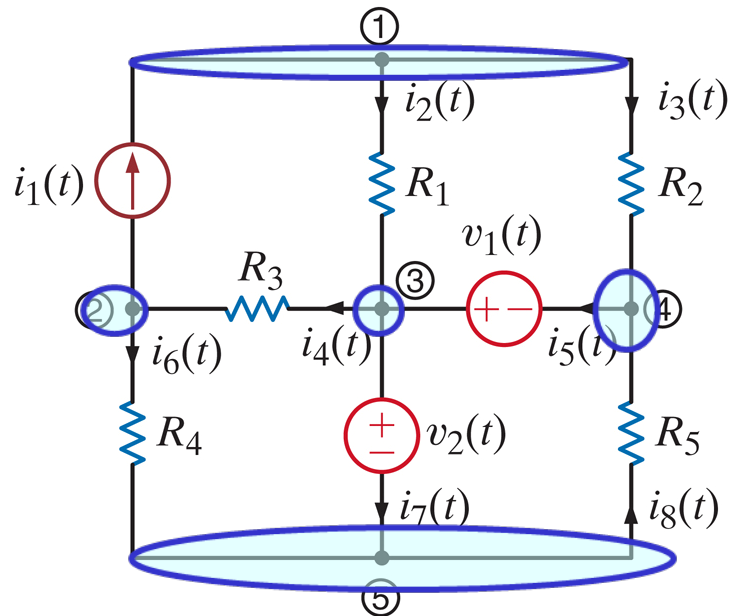

$$-i_1(t) + i_2(t) + i_3(t) = 0$$

$$i_1(t) - i_4(t) + i_6(t) = 0$$

$$-i_2(t) + i_4(t) - i_5(t) + i_7(t) = 0$$

$$-i_3(t) + i_5(t) - i_8(t) = 0$$

$$-i_6(t) - i_7(t) + i_8(t) = 0$$

THE FIFTH EQUATION IS THE SUM OF THE FIRST FOUR... IT IS REDUNDANT!!!

FIND MISSING CURRENTS

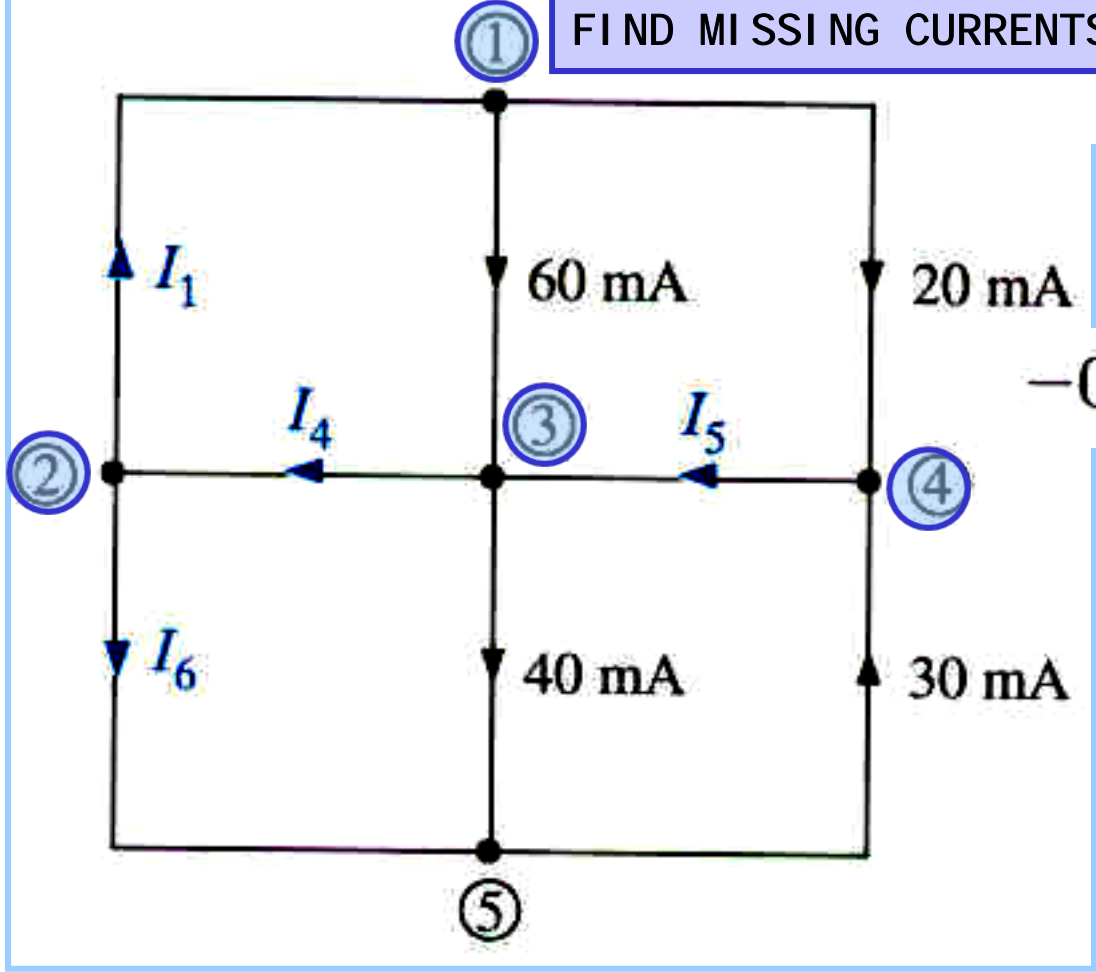

$$-I_1 + 0.06 + 0.02 = 0$$

$$I_1 - I_4 + I_6 = 0$$

$$-0.06 + I_4 - I_5 + 0.04 = 0$$

$$-0.02 + I_5 - 0.03 = 0$$

KCL DEPENDS ONLY ON THE INTERCONNECTION.
THE TYPE OF COMPONENT IS IRRELEVANT

KCL DEPENDS ONLY ON THE TOPOLOGY OF THE CIRCUIT

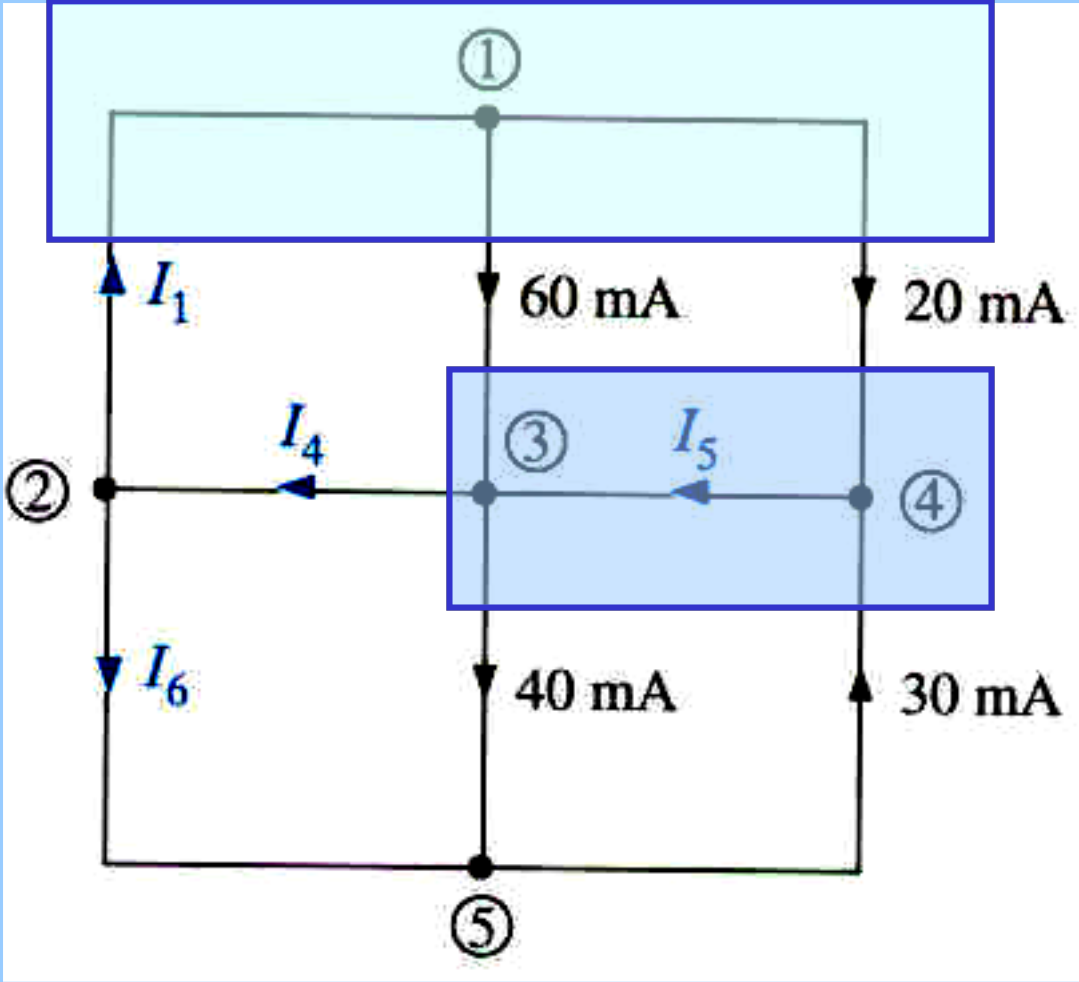

Here we illustrate the use of a more general idea of node. The shaded surface encloses a section of the circuit and can be considered as a BIG node

SUM OF CURRENTS LEAVING BIG NODE = 0

$$I_4 + 40mA - 30mA - 20mA - 60mA = 0$$

$$I_4 = 70mA$$

THE CURRENT I5 BECOMES INTERNAL TO THE NODE AND IT IS NOT NEEDED!!!

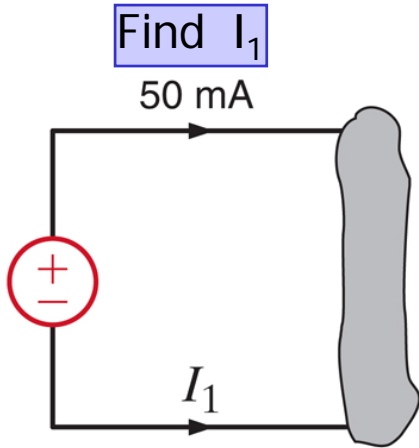

$$I_1 = -50 \text{ mA}$$

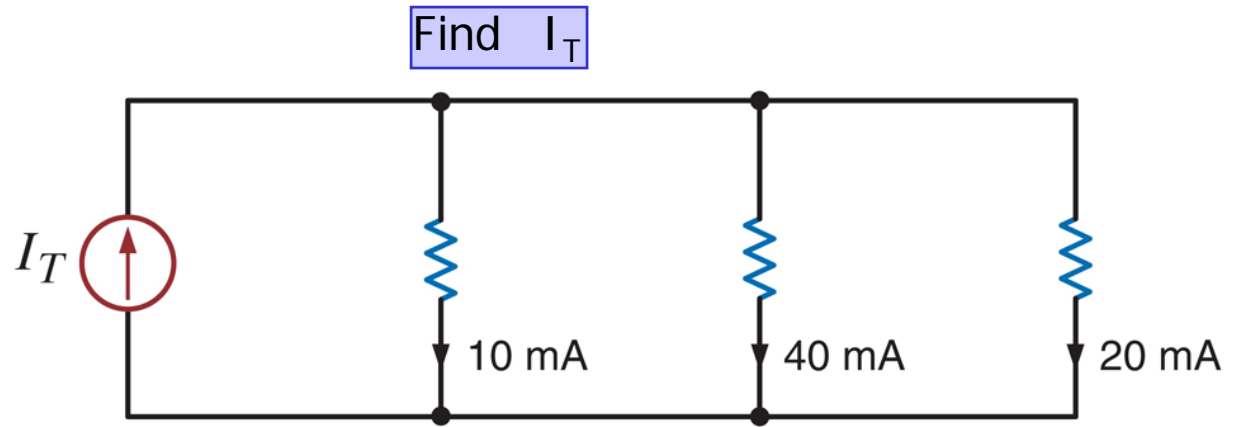

$$I_T = 10 \text{ mA} + 40 \text{ mA} + 20 \text{ mA}$$

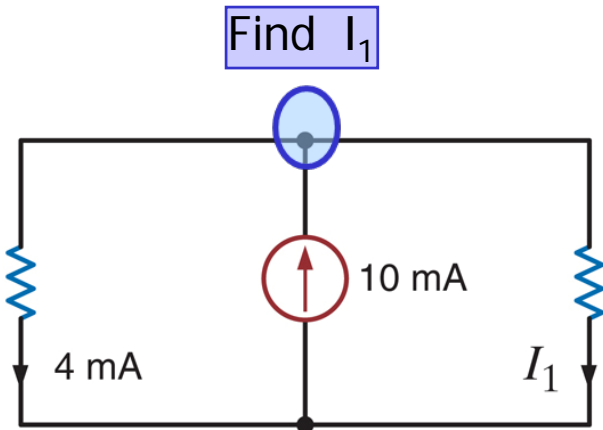

$$10 \text{ mA} - 4 \text{ mA} - I_1 = 0$$

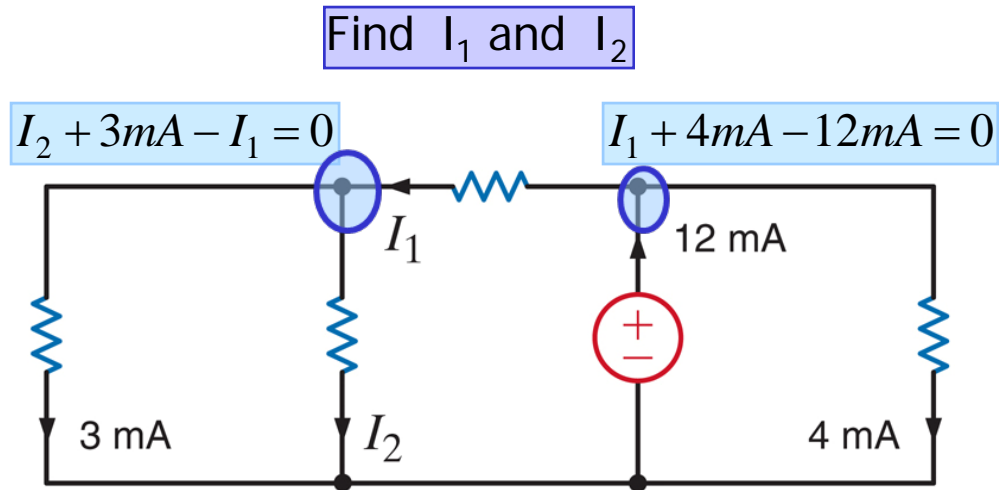

KIRCHHOFF VOLTAGE LAW

ONE OF THE FUNDAMENTAL CONSERVATION LAWS
IN ELECTRICAL ENGINEERING

THIS IS A CONSERVATION OF ENERGY PRINCIPLE
"ENERGY CANNOT BE CREATED NOR DESTROYED"

KIRCHHOFF VOLTAGE LAW (KVL)

KVL IS A CONSERVATION OF ENERGY PRINCIPLE

A POSITIVE CHARGE GAINS ENERGY AS IT MOVES TO A POINT WITH HIGHER VOLTAGE AND RELEASES ENERGY IF IT MOVES TO A POINT WITH LOWER VOLTAGE

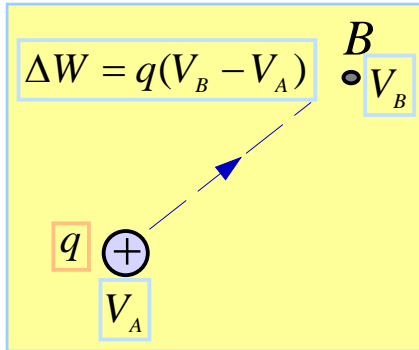

A "THOUGHT EXPERIMENT"

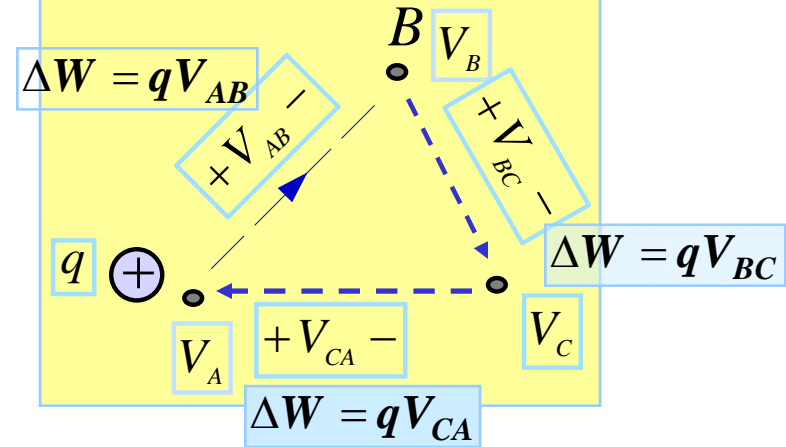

IF THE CHARGE COMES BACK TO THE SAME INITIAL POINT THE NET ENERGY GAIN MUST BE ZERO (Conservative network)

OTHERWISE THE CHARGE COULD END UP WITH INFINITE ENERGY, OR SUPPLY AN INFINITE AMOUNT OF ENERGY

$$q(V_{AB} + V_{BC} + V_{CD}) = 0$$

KVL: THE ALGEBRAIC SUM OF VOLTAGE DROPS AROUND ANY LOOP MUST BE ZERO

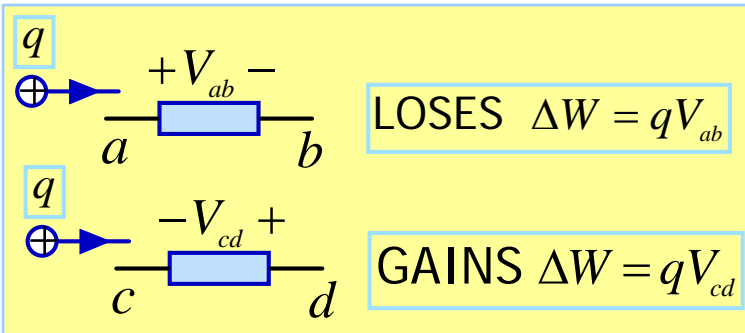

$$\text{A} \quad -V \quad + \quad \text{B} \quad \equiv \quad \text{A} \quad +(-V) \quad - \quad \text{B}$$

A VOLTAGE RISE IS
A NEGATIVE DROP

Write the KVL equation for the following loop, traveling clockwise:

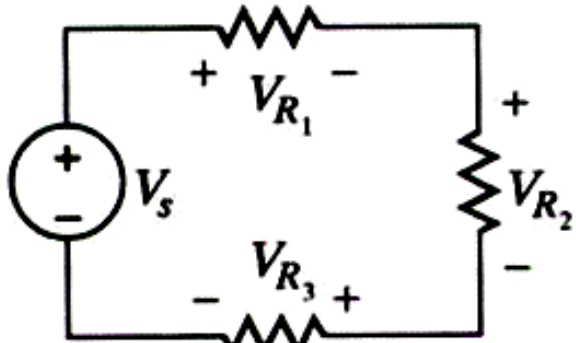

$$-V_S + V_{R_1} + V_{R_2} + V_{R_3} = 0$$

PROBLEM SOLVING TIP: KVL IS USEFUL TO DETERMINE A VOLTAGE - FIND A LOOP INCLUDING THE UNKNOWN VOLTAGE

THE LOOP DOES NOT HAVE TO BE PHYSICAL

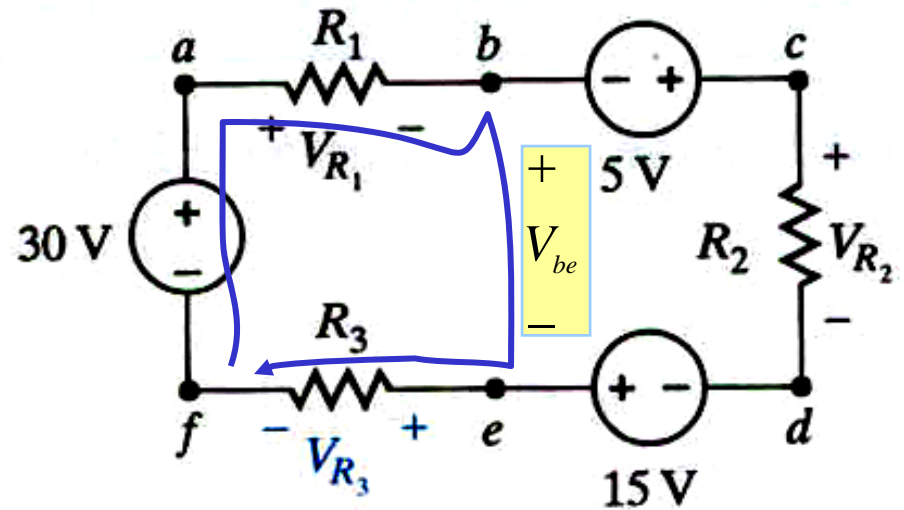

EXAMPLE: V_{R_1}, V_{R_3} ARE KNOWN
DETERMINE THE VOLTAGE V_{be}

$$V_{R_1} + V_{be} + V_{R_3} - 30[V] = 0$$

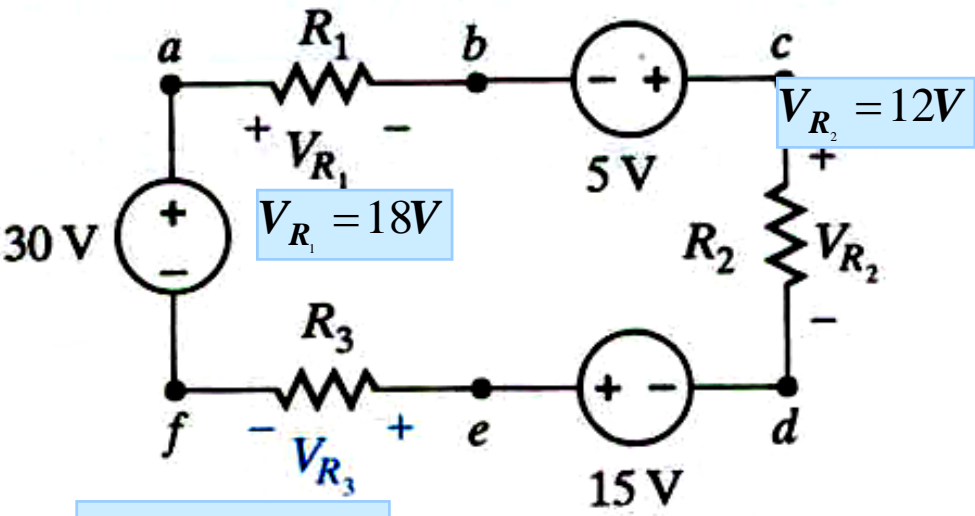

LOOP abcdefa

$$+V_{R_1} - 5 + V_{R_2} - 15 + V_{R_3} - 30 = 0$$

BACKGROUND: WHEN DISCUSSING KCL WE SAW THAT NOT ALL POSSIBLE KCL EQUATIONS ARE INDEPENDENT. WE SHALL SEE THAT THE SAME SITUATION ARISES WHEN USING KVL

A SNEAK PREVIEW ON THE NUMBER OF LINEARLY INDEPENDENT EQUATIONS

IN THE CIRCUIT DEFINE

N NUMBER OF NODES

B NUMBER OF BRANCHES

$N - 1$ LINEARLY INDEPENDENT KCL EQUATIONS

$B - (N - 1)$ LINEARLY INDEPENDENT KVL EQUATIONS

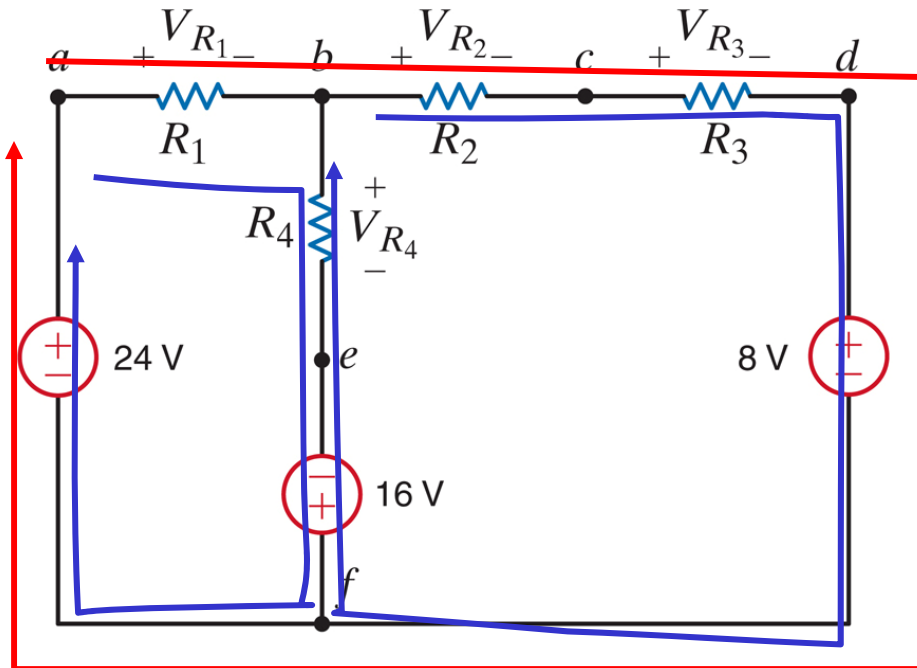

EXAMPLE: FOR THE CIRCUIT SHOWN WE HAVE $N = 6$, $B = 7$. HENCE THERE ARE ONLY TWO INDEPENDENT KVL EQUATIONS

$$V_{R_1} + V_{R_4} - 16 - 24 = 0$$

$$V_{R_2} + V_{R_3} + 8 + 16 - V_{R_4} = 0$$

$$V_{R_1} + V_{R_2} + V_{R_3} + 8 - 24 = 0$$

THE THIRD EQUATION IS THE SUM OF THE OTHER TWO!!

FIND THE VOLTAGES V_{ae} , V_{ec}

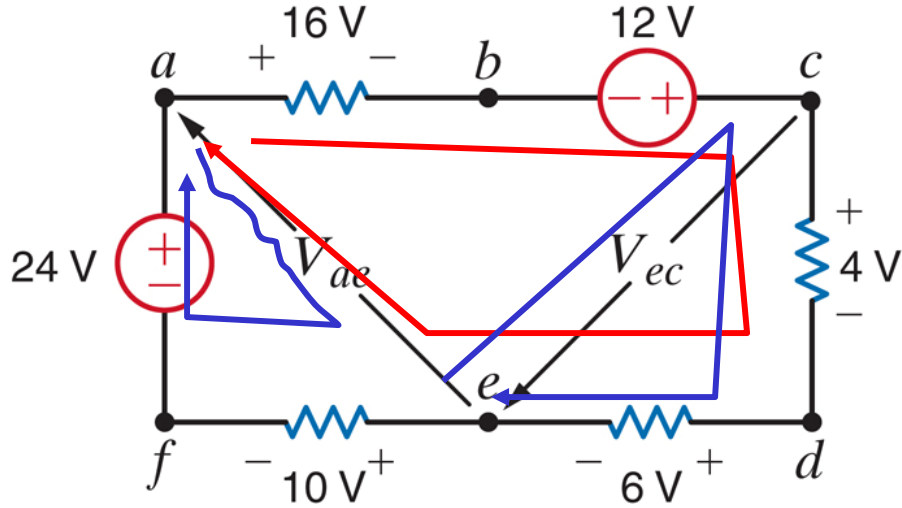

$$V_{ae} + 10 - 24 = 0$$

$$16 - 12 + 4 + 6 - V_{ae} = 0$$

GIVEN THE CHOICE USE THE SIMPLEST LOOP

$$4 + 6 + V_{ec} = 0$$

SAMPLE PROBLEM

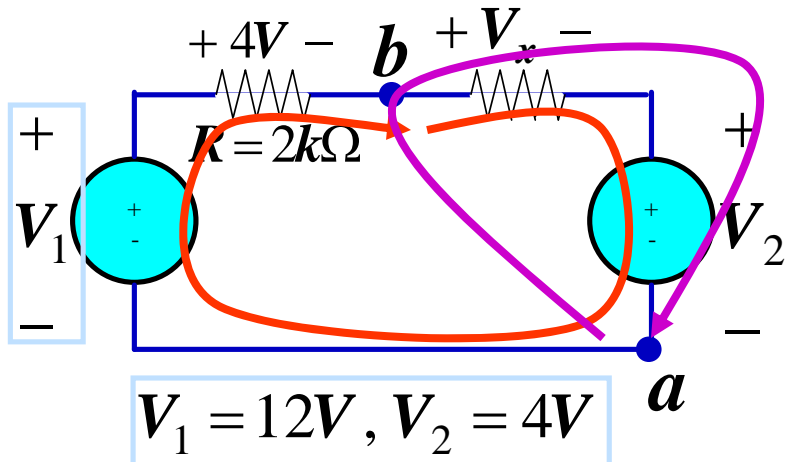

DETERMINE

$$V_x = 4V$$

$$V_{ab} = -8V$$

Power dissipated on
the 2k resistor

$$P_{2k} =$$

Remember
past topics

We need to find a closed path where only one voltage is unknown

FOR V_x

$$V_x + V_2 - V_1 + 4 = 0$$

$$V_x + 4 - 12 + 4 = 0$$

$$V_x + V_2 + V_{ab} = 0$$

$$V_{ab} = -V_x - V_2$$