



IN THIS ISSUE

- Comparing the accuracy and repeatability of on-wafer calibration techniques to 110 GHz
- Measuring the Amplitude and Phase Balance of an IQ Demodulator Using the Agilent 8720ES Vector Network Analyzer
- Improving your transmission measurement accuracy with enhanced response calibration



New name... *Same world-class commitment*

As you might suspect, we at Agilent Technologies have undergone a great number of changes recently, from the moment we announced the impending split from our parent company Hewlett-Packard. Even today, a few of us still catch ourselves answering the phone with a “Good morning, Hewlett-Packard.” However, change is inevitable and challenging... an energizing catalyst for reevaluation and growth. Our pledge is to support you in the HP style, with a renewed spirit of innovation.

With our 8510/8720 News, we'd like to give you the opportunity to provide your feedback on its value and future direction. Tell us about changes in your business climate that may inspire us to change the direction, content, and perhaps even the format of the newsletter to better meet your needs. We need your input. We've included a survey and ask that you take a few minutes to check the boxes and return it to us.

We are bringing you this issue of the 8510/8720 News unchanged from prior issues, with the exception of the new Agilent “spark” logo. Our focus in this issue: measurement accuracy. In today's expanding and congested communications industry, accurate measurements are more important than ever. Improving measurement accuracy can increase product yields and overall product reliability, positively affecting your bottom line.

Our channel partner, Cascade Microtech, has contributed the feature article this month. It is an in-depth, comparative study of on-wafer calibration techniques to 110 GHz, focusing on methods and results of on-wafer measurements in millimeter wave.



Leo Barclay
Component Test Product Marketing Manager,
Agilent Technologies

The Agilent 8510XF system (E7350A), with its 45 MHz to 110 GHz broadband frequency coverage, is an ideal tool when measuring broadband devices on-wafer or coax.

We've included an article on measuring the amplitude and phase balance of an IQ demodulator. With digital communication receivers, the quality of the received data is partly a function of the performance of the IQ demodulator used in the system.

Our “Tips & Techniques” column looks at improving transmission measurement accuracy by using the enhanced-response calibration feature of the Agilent 8720E.

We hope that this issue of the 8510/8720 News provides you with solutions to the problems you must solve. Please take a moment to complete our survey so we know whether we're providing the content you need.



Agilent Technologies
Innovating the HP Way

Comparing the accuracy and repeatability of on-wafer calibration techniques to 110 GHz

Many methods of making corrected S-parameter measurements are available for on-wafer devices and circuits. Following is a comparative study of calibration techniques, presented as most accurate and repeatable for making on-wafer measurements.

An ongoing concern when making on-wafer calibrations and measurements is the accuracy and repeatability of the measurements you're making. Because of the complexity and diversity of the measurement system, it makes traceability back to a physical reference impractical. We can, however, compare the complete measurement system, including probes, calibration standards, and algorithms, to a benchmark standard defined by the National Institute of Standards and Technology (NIST). With the growing interest in millimeter-wave devices due to growth in the aerospace, automotive, and optical industries, it is important to understand which calibration setup will offer the most superior measurement performance for any particular application.

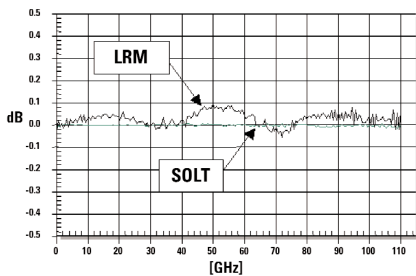

Figure 1. Measurement of open standard after calibration falsely shows SOLT to be perfect, which is a result of the SOLT calibration forcing the reflections to be 0.0 dB

To identify the true integrity of the SOLT calibration we require independent verification standards. Re-measuring the same standards will only show the repeatability of the contact. This is shown in Figure 1. The SOLT calibration is not self-consistent and the open circuit response shows a perfect reflection, where the LRM calibration method is self-consistent and errors can be identified looking at the magnitude of S11. It is not a safe assumption to believe SOLT is more accurate because it looks like a perfect open.

What were the methods and their limitations?

Three different calibration standard substrates were used for the comparisons: One GaAs substrate for the NIST Multi-Line (LRL) calibration¹, and two alumina substrates for Short-Open-Load-Through (SOLT), Line-Reflect-Match (LRM) and Line-Reflect-Reflect-Match (LRRM) calibrations. One alumina substrate was 625 μm thick, and the other 250 μm thick. It was recommended² that the thin ISS include a layer of Radiation Absorption Material (RAM) between the Impedance Standard and metal chuck surface.



Anthony J. Lord
European Sales Executive
Cascade Microtech, Europe Ltd.

A major limitation is lack of a reliable precision reference measurement to 110 GHz. It became necessary to extrapolate from previous results³ to cover the higher frequency bond. The NIST LRL calibration standards are not a modelled 50 ohm transmission line to 110 GHz, and a mismatch to 50 ohm calibrations can be expected. Our LRL calibration reference planes were at the center of the 500 μm through line, and the Zo was referenced to the line. To compare the common calibration methods used by engineers today for on-wafer microwave measurements, we performed several calibrations using SOLT, LRM, LRRM with Auto Load Inductance Compensation⁴, and LRL. Measurements were collected, using each resulting calibration co-efficients, of both active and passive devices to determine if a measurement difference was apparent by using different techniques. A commercially available software package⁵ was used for performing calibrations and recording measurements.

• *continued*

Comparing the accuracy and repeatability of on-wafer calibration techniques to 110 GHz *continued*

The measurements and results

Open circuit measurement

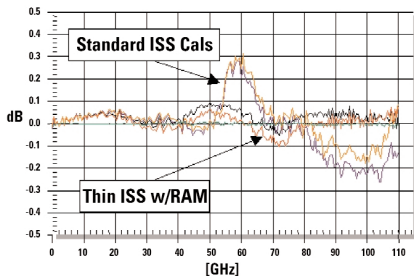

Figure 2. Measurement of open standard after SOLT, LRM and LRRM calibrations

The open standard measurements using the SOLT calibration coefficients indicate a near perfect reflect, since we are only performing a repeatability measurement of the contact. The thinned 250 μm ISS and layer of RAM material reduced the magnitude of error on both LRM and LRRM calibrations. The large error using the 625 μm thick ISS was due to the substrate mode being more significant at millimeter wave frequencies. The 250 μm ISS pushes the substrate mode above 110 GHz. This now meets the commonly used error limits of ± 0.1 dB for open circuit verification.

Open stub measurement

A more reliable way of verifying the integrity of the calibration is to measure an independent verification standard. We used a 3.2 mm open stub and 3.2 mm line of the NIST reference substrate. The ISS calibrations, using both the 625 μm and 250 μm thick substrates, show a ripple effect. This is due to the line not being exactly 50 ohms, and is mismatched to our 50 ohm ISS calibrations. The LRL calibration shows a more linear response, but a phase and magnitude offset is present due to the reference plane being in the center of the LRL through line, not the probe tips, as with the ISS calibrations.

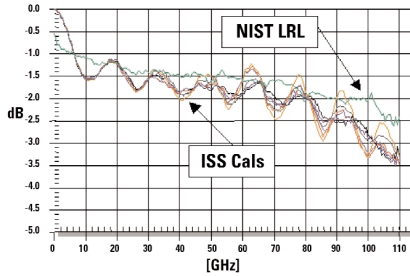

Figure 3. S11 LogMag measurement of 3.2 mm open stub

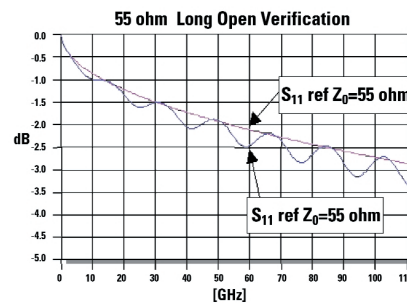

Figure 4. Model of 3.2 mm open verification standard, making the assumption that the GaAs line is not 50 ohms

Line measurement

The GaAs line measurement shows the LRL being comparable to the ISS-based calibrations up to 70 GHz, where afterwards the ISS calibrations show greater loss. This may be a result of the mismatched line acting as a low-pass filter for the 50 ohm calibrations.

• *continued*

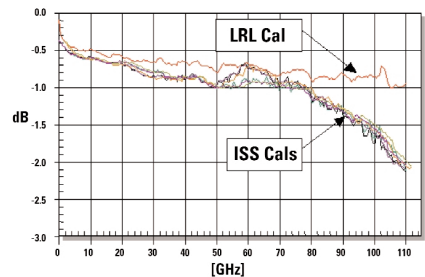

Figure 5. S21 LogMag measurement of NIST 3.2 mm line

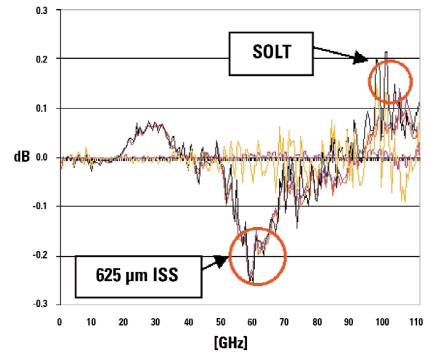

Figure 6. LogMag variations of line using LRRM/250 μm ISS as reference (ISS calibrations only)

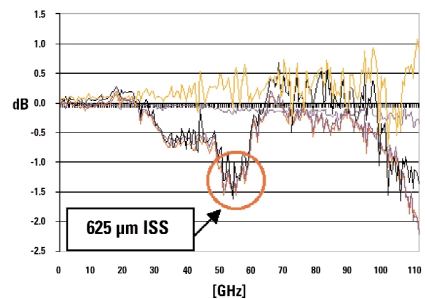

Figure 7. Phase variation of line using LRRM/250 μm ISS as reference (ISS calibrations only)

Comparing the accuracy and repeatability of on-wafer calibration techniques to 110 GHz *continued*

The ISS calibrations have approximately the same deviation from the LRL measurement, as shown in Figure 5. Using the LRRM calibration as a reference, the variation of the LRM and SOLT calibrations can be observed. The 625 μm ISS and SOLT calibrations show greater variation in phase and magnitude. The phase variation of the ISS calibrations from the LRL calibration shows a linear phase change due to the reference planes of our LRL calibration being the center of the 500 μm through standard and not the tip of the probes, as with the ISS calibrations.

Field effect transistor (FET) measurement

The measurement accuracy very much relies on the calibration and the measurement application. Figure 8 shows a measurement made of a GaAs FET device. The SOLT, LRM and LRRM calibrations are grouped together. The only stray measurements are the NIST LRL calibration. The difference between the LRL and other calibrations is probably not due to inaccuracy of the ISS-based calibrations. It is likely due to the inaccuracy of the LRL calibration due to the change in pad parasitic, the change of effective dielectric constants and the low-end limitation of the calibration due to the restrictions of long-line standards.

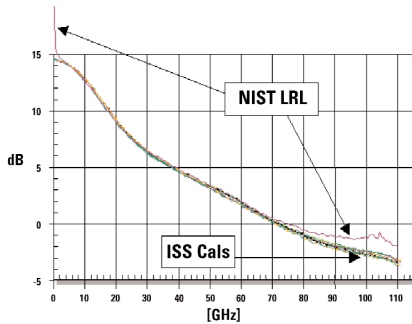

Figure 8. Measurements of a GaAs FET device

The SOLT calibration performed on the 250 μm ISS indicates a linear increase in magnitude and phase (Figures 9 and 10). The SOLT, LRM and LRRM calibrations performed on the 625 μm ISS show the same errors when measuring the open circuit during calibration verification. Only the LRM calibration made on the 250 μm ISS is comparable to the LRRM reference calibration.

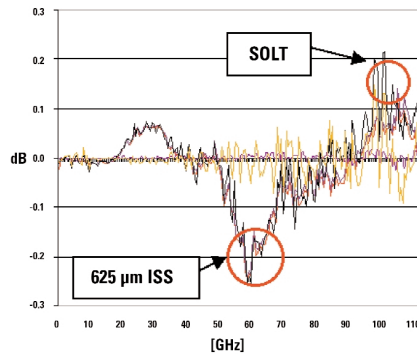

Figure 9. S21 LogMag variation of GaAs FET device with reference to LRRM calibration using 250 μm ISS

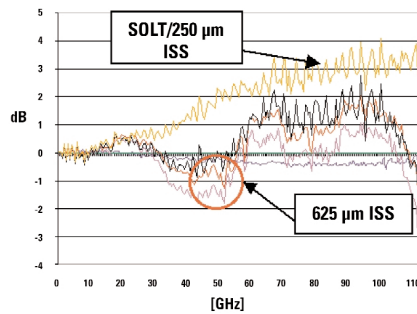

Figure 10. S21 Phase variation of GaAs FET device with reference to LRRM calibration using 250 μm ISS

Repeatability of calibrations

The need to make an accurate calibration and measurement is equalled by the requirement to make repeatable calibrations and measurements. Figures 11 and 12 show the worst-case error bounds for repeating two identical calibration techniques. The results show that the LRRM calibration with load inductance compensation was more repeatable than SOLT, which was particularly sensitive when using different sets of standards.

• *continued*

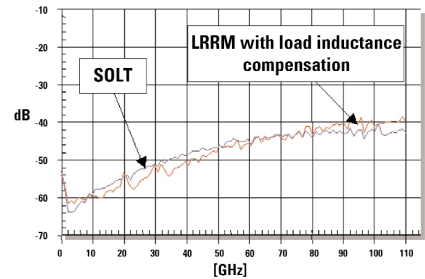

Figure 11. The worst-case errors for calibration repeatability using the same set of standards

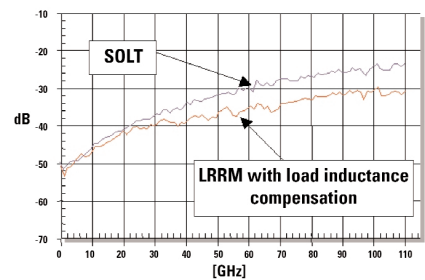

Figure 12. The worst-case errors for calibration repeatability using two different sets of standards

Comparing the accuracy and repeatability of on-wafer calibration techniques to 110 GHz *continued*

We performed eight LRRM calibrations using the same set of ISS standards, but replacing the probes manually on the ISS alignment mark. Even though our probe placement was not exact due to the limitation of the optics and resolution of the positioners, the open standard verification has a worst-case spread of 0.15 dB. The same experiment was repeated using eight different sets of standards. The repeatability of calibration was decreased, but only marginally, to 0.2 dB. All the calibration verifications were within the generally recommended limits of +/- 0.1 dB up to 110 GHz. Open measurements phase error is expected to be more sensitive to probe placement errors causing small changes in reference plane location.

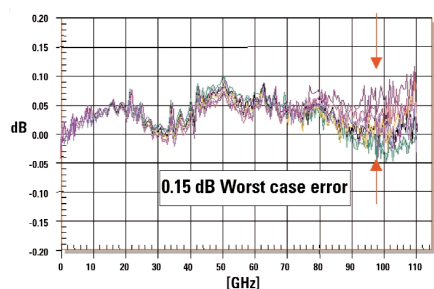

Figure 13. S11 open measurement of eight LRRM calibrations

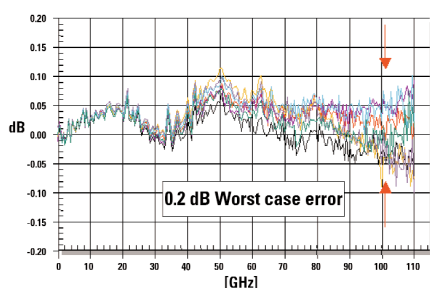

Figure 14. S11 open measurement of eight LRRM calibrations using different sets of calibration

Our conclusions

Analysis of the measurements showed differences in magnitude and phase of the devices under test (DUT). The extent of the differences was found to be dependent on the DUT and calibration technique used.

From the measurements made of the open stub and line, on the GaAs NIST reference material, the results approximated what we expected. The ISS calibrations did not have the same Z_0 as the GaAs line. This resulted in a loss increasing with frequency combined with a ripple effect. The LRL measurement did not exhibit the ripple, because the Z_0 of the calibration was the same as the line, but had an offset in phase and magnitude due to the incorrect positioning of the reference planes.

The FET device results identified large variations at low and high frequencies between the LRL calibration and the ISS-based calibrations. The low-end variation was a limitation due to the line length required for low frequencies and the large imaginary component of the characteristic impedance at low frequencies due to conductor resistance. The high frequency was a result of differences in pad parasitic between the calibration standard and DUT.

The 625 μm -thick ISS exhibited a larger error in magnitude when verifying the calibration, using an open standard. This error is noticeable when measuring a reflective DUT such as an open or open stub, and was also noticeable on the S21 of a FET measurement.

While performing the calibrations, we observed how essential probe placement accuracy is for all calibration methods, especially when making LRL and SOLT calibrations. The probe placement error was not critical when using load inductance compensation, which was used for the LRRM measurements. Several calibration attempts were required to achieve satisfactory results for the techniques not using load inductance compensation. In fact, we encountered long and tedious problems trying to achieve a “good” NIST LRL calibration, and it was not easy to achieve repeatability.

Also while making our calibrations, we noted that a good LRRM calibration with load inductance compensation was achieved after every attempt. The repeatability of making numerous LRRM calibrations proved to be better than -30 dB of repeatability, even when using different sets of standards.

References

1. Roger Marks, A multi-line method of network analyzer calibration, IEEE Trans. On MTT, Vol. 39, No. 7, pp. 1205-1215, July 1991.
2. Ed Godshalk, Surface wave phenomenon in wafer probing environments, 40th ARFTG Conference Digest, Dec. 1992.
3. Cascade Microtech Inc., Technique Verifies LRRM Calibrations for GaAs Measurements.
4. John Pence, Verification of LRRM calibrations with load inductance compensation for CPW measurements on GaAs substrates, 42nd ARFTG Conference Digest, Nov. 1993.
5. WinCal 2.30 Calibration and Measurements Tool, Commercial Product, Cascade Microtech Inc.

Measuring the amplitude and phase balance of an IQ demodulator using the Agilent 8720ES vector network analyzer

When working with digital communication receivers, the quality of the received data is partly a function of the performance of the IQ demodulator used in the system. A typical IQ demodulator performs downconversion of a high-frequency modulated carrier and outputs separate I (in-phase) and Q (quadrature) data streams. (See Figure 1.)

The input RF frequency is split into two separated channels using an internal power divider. Each channel has a separate frequency translation device (FTD) used to downconvert the RF signal to baseband. The Local Oscillator (LO) is applied to the two FTDs with a 90-degree LO phase difference between the two channels. So the input signal is broken down into an I and a Q component¹. These two IF signals are independent and orthogonal. When properly designed, the I and Q ports will have an equal amplitude balance with a phase difference of 90 degrees.

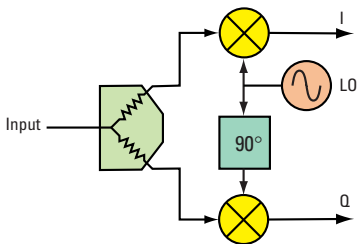

Figure 1. IQ demodulator block diagram

It is important that amplitude and phase balance be maintained over the IF or baseband frequency range, as any imbalance will degrade the performance of the digital receiver. For example, Figure 2 shows an Agilent EEsof ADS simulation of the I channel output of a communication system using unfiltered data with Q PSK modulation. The output data stream shown in the figure is created from an IQ demodulator for the case of an ideal demodulator and a case with a 5-degree phase imbalance between the I and Q ports. For the case with 5-degree phase imbalance, the I channel data stream shows a small leakage signal from the Q channel because the two signals are not perfectly orthogonal. This signal leakage will degrade the system performance resulting in a higher error vector magnitude (EVM) and poorer bit error rate (BER).



Michael E. Knox
Technical Consultant
Test and Measurement, SSU

Calibrating the 8720ES vector network analyzer over the IF range

The IQ demodulator amplitude and phase balance can be easily measured using the frequency offset mode on the Agilent 8720ES (with option 089). The IQ demodulator has a single RF input and two IF frequency outputs. Port 1 of the 8720ES supplies the RF input to the IQ demodulator. The analyzer is configured to measure one IF output on the R channel and the other IF signal on the B channel. The R channel is used to phase-lock the system in frequency offset mode. The signal level to the R channel must be between 0 and -35 dBm, for both calibration and test, for proper phase-locking. A standard S21 (B/R) measurement will show both the amplitude and phase balance through the IQ demodulator.

• continued

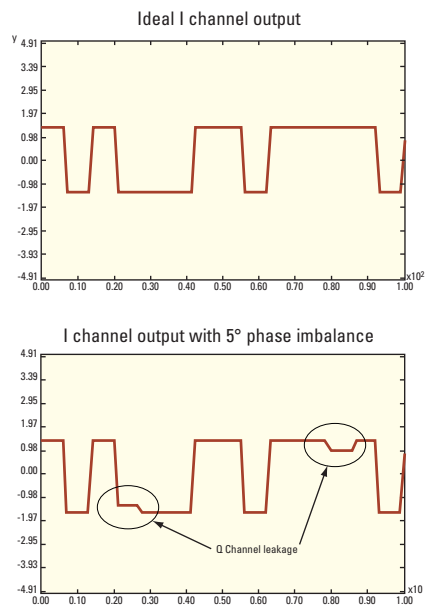

Figure 2. IQ demodulator I channel data output showing effects of phase imbalance

Measuring the amplitude and phase balance of an IQ demodulator using the Agilent 8720ES vector network analyzer *continued*

Before the measurement can begin, the system's R and B channels need to be calibrated over the IF frequency range of the demodulator. This step can be easily performed using a simple two- or three-resistive splitter such as the 11636B or 11667B. We show the calibration setup in Figure 3. Here the splitter is used to equally divide the input signal from Port 1 between Port 2 and R IN on the 8720ES. For our example, the IF frequency will be selected from 100 MHz to 200 MHz. The frequency offset mode is activated over the IF range with LO of 0 Hz on the 8720ES. A simple S21 response cal will be used to calibrate the analyzer's B/R measurement over the IF frequency range.

Here are the required keystrokes to activate the frequency offset mode and calibrate the analyzer over the IF range:

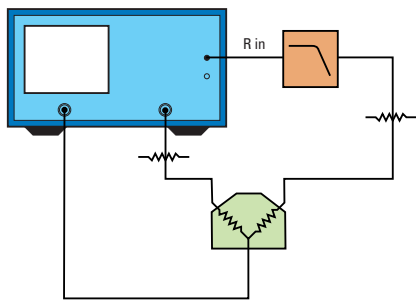

Figure 3. Configuration for calibrating the IF

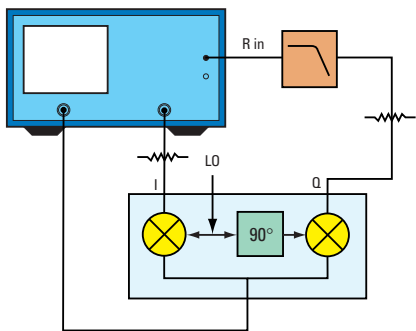

Figure 4. Configuration for measuring the IQ demodulator

```
MEAS, S21(B/R), SYSTEM,
INSTRUMENT MODE, FREQ OFFS,
MENU, DOWNCONVERTER, RF>LO,
START 100 MHz, STOP 200 MHz,
LO FREQ, 0 Hz
FREQ OFFS ON,
(Disconnect the R channel jumper and
connect the splitter to the instrument)
CAL, CALIBRATE MENU, RESPONSE,
THRU
```

The accuracy of the calibration depends primarily on the amplitude and phase balance of the splitter. A typical resistive splitter, such as the 11636B, is specified with an amplitude and phase balance of 0.5 dB and +/- 2 degrees respectively over a frequency range of DC to 26.5 GHz². For the calibration, the splitter is typically used over a very low IF frequency range, resulting in an actual amplitude and phase balance well below these specs. For instance, the 11636B splitter used in this example was measured to be 0.05 dB and 0.1 degree in amplitude and phase tracking respectively over the frequency range of 100 MHz to 200 MHz. These values of amplitude and phase tracking are suitable for most IQ demodulator measurements. Additional measurement uncertainty can result from the mismatch errors created between the analyzer's test ports and the output of the splitter or IQ demodulator. By placing attenuators between the analyzer and the device under test, you can reduce the size of the uncertainty.

For example, using a 6 dB pad on each test port, the worst-case measurement uncertainty caused by mismatch errors during calibration and test will be less than 0.08 dB and 0.5 degrees. These values were calculated using the specified port match for the Agilent 8720 and 11636B splitter and a 2:1 VSWR for the I and Q ports of the demodulator. The mismatch errors can be further improved using larger values of attenuation at the expense of dynamic range. No attenuation is required on the input to the splitter because the mismatch error introduced here will appear equally at both test ports and ratioed out of the calibration and test.

You should use an IF low-pass filter to ensure proper phase-locking in the R channel and to reduce any spurious signals that may appear in the measurement. A second IF filter may be required in the B channel if additional spurious signals are present in the measurement. These filters should be placed in the measurement path prior to system calibration to remove their effects from the test. During the test, access to the LO is not required for the measurement. This is very useful for demodulators that have internal oscillators. The 8720ES will phase-lock onto the incoming IF signal and generate the proper RF stimulus for the input to the IQ demodulator.

• *continued*

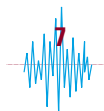

Measuring the amplitude and phase balance of an IQ demodulator using the Agilent 8720ES vector network analyzer **continued**

Performing measurements on the IQ demodulator

Once the system is calibrated, the splitter is removed and the IQ demodulator is placed into the measurement path as shown in Figure 4. The LO setting on the 8720ES is changed to reflect the actual LO applied to the demodulator. For our example, the LO frequency is set to 2.4 GHz with results in an RF frequency of 2.5 to 2.6 GHz. (Note: The analyzer will display a phase-lock error message until the proper LO setting is entered on the 8720ES and the demodulator is placed in the system.) The 8720ES keystrokes for measuring the amplitude and phase balance of the IQ demodulator are:

SYSTEM, INSTRUMENT MODE, FREQ OFFS MENU, LO FREQ, LO 2.4 GHz, FORMAT, LOG MAG or PHASE

The system will now display the amplitude and phase balance for the IQ demodulator. For the demodulator used in our example, the amplitude and phase balance are shown in Figures 5 and 6 respectively. The measured amplitude balance is -0.25 dB with about +/- 0.1 dB variation and the phase balance is 90 degrees with a +/- 0.4 degrees peak variation over the IF frequency range of 100 MHz to 200 MHz.

If you require downconversion to lower frequencies, the same approach can be used with the Agilent 8753ES for measurements as low as 300 kHz.

References:

1. Agilent Application Note 1298, *Digital Modulation in Communication Systems – An Introduction*.
2. Agilent RF & Microwave Test Accessories 1999/2000 Catalog.

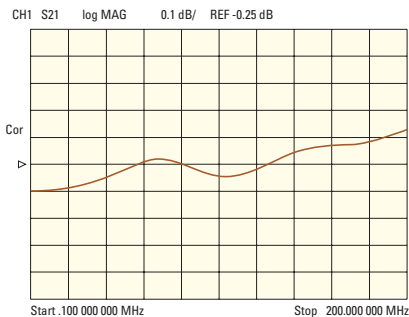

Figure 5. IQ demodulator magnitude balance

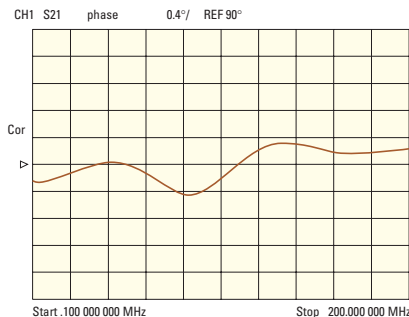
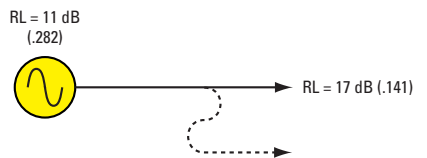

Figure 6. IQ demodulator phase balance

Improve your transmission measurement accuracy with enhanced response calibration

For two-port transmission measurements, a response calibration offers simplicity, but with some compromise on accuracy. Response calibration is a normalized measurement in which a reference trace is stored in the network analyzer's memory, and the stored trace is divided into measurement data for normalization.

With the Agilent 8720E family of microwave network analyzers, you can perform an *enhanced response calibration*. By combining a response calibration with reflection correction, additional error terms are corrected to minimize overall measurement uncertainty.



Thru calibration (normalization) builds error into measurement due to source and load match interaction

$$\begin{aligned} \text{Calibration uncertainty} &= (1 \pm \rho_{SP1}) \\ &= (1 \pm (.282)(.141)) \\ &= +.034 \text{ dB}, -.035 \text{ dB} \end{aligned}$$

Figure 1. Transmission example using response cal

Reviewing the sources of measurement error

Measurement calibration is a process for improving measurement accuracy by using error correction arrays to compensate for systematic measurement errors.

Measurement errors are classified as random, drift, and systematic errors. Random errors, such as noise and connector repeatability, are nonrepeatable and not correctable by measurement calibration. Drift errors, such as frequency and temperature drift, are also nonrepeatable and not fully correctable by calibration.



Rudy Gloria
Product Marketing
Agilent Technologies

Systematic errors, such as tracking and crosstalk, are the most significant errors in most microwave measurements. Fortunately, systematic errors are repeatable and for the most part correctable, though small residual errors may remain.

Repeatable systematic errors are due to system frequency response, isolation between the signal paths, and mismatch and leakage in the test setup.

Frequency response errors (transmission and reflection tracking) are errors that are a function of frequency.

Isolation errors result from energy leakage between signal paths. In transmission measurements, this leakage is due to crosstalk. In reflection measurements, it is due to imperfect directivity.

Mismatch errors result from differences between the device under test's (DUT's) port impedance and the analyzer's port impedance. Source match errors are produced on the source side (network analyzer's Port 1) of the DUT; load match errors are produced on the load side (network analyzer's Port 2). If the DUT is not connected directly to the port, the mismatch errors due to cables, adapters, etc. are considered part of the source or load match errors.

Improve your transmission measurement accuracy with enhanced response calibration **continued**

Performing a transmission response calibration

In making a transmission measurement using only response calibration, the first step is to make a through connection between the two test ports (with no DUT in place). For this example, a typical filter and test port

specification for the 8720ET will be used. The ripple caused by this amount of mismatch is calculated as +0.34/-0.35 dB, and is now present in the reference data (Figure 1). It must be added to the uncertainty when the DUT is measured, in order to compute worst-case overall measurement uncertainty.

After adding the filter into the test setup, additional signal interactions can be identified. There are three main error signals caused by reflections between the ports of the analyzer and the DUT (Figure 2). Higher-order reflections can be overlooked because they are small compared to the three main terms.

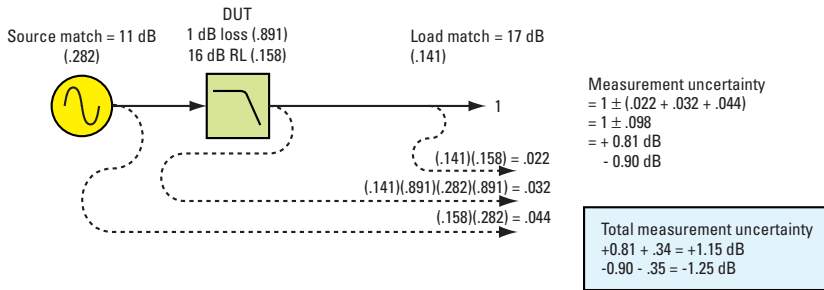

Figure 2. Transmission example

One of the error signals passes through the filter twice, so it is attenuated by twice the insertion loss. A worst-case condition occurs when all of the reflected error signals add together in phase ($0.022 + 0.032 + 0.044 = 0.098$). In that case, measurement uncertainty is +0.81/-0.90 dB. Total measurement uncertainty, which must include the 0.35 dB of error incorporated into the calibration measurement, is about ± 1.25 dB.

• continued

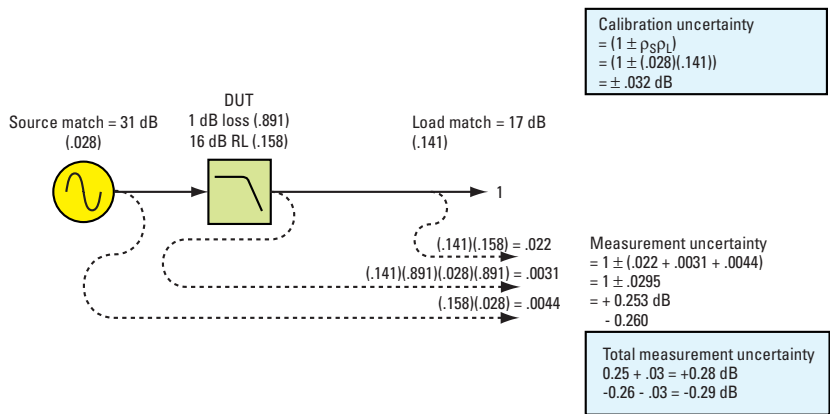

Figure 3. Transmission measurements using enhanced response calibration

Improve your transmission measurement accuracy with enhanced response calibration **continued**

Performing an enhanced response calibration

The enhanced response calibration requires the measurement of short, open and load standards on Port 1, and a through standard between Ports 1 and 2 for transmission measurements. By combining a one-port calibration and a response calibration, the analyzer is now able to correct for source match errors during transmission measurements.

The enhanced response calibration (Figure 3) improves the effective source match compared during transmission measurements to about 31 dB, compared to 11 dB for normal response calibrations. This reduces the calibration error from ±0.35 dB to

±0.034 dB, and greatly reduces the two measurement error terms that involve interaction with the effective source match. The total measurement error is ±0.29 dB, instead of the previous value of ±1.25 dB for a standard response calibration.

It's possible to further reduce measurement uncertainty. Enhanced response calibration corrects for source match but not load match. An attenuator on Port 2 will reduce the mismatch signal interaction (Figure 4), resulting in an effective load match of 24.5 dB. The effects of the attenuator must be included in the overall measurement uncertainty. In this example, a 6 dB pad results in an overall uncertainty of ±0.15 dB, compared to ±0.29 dB without its use.

How does this compare to two-port error calibration?

Two-port error correction yields the most accurate results because it accounts for all six forward and six reverse sources of systematic error. The mathematical equations used to derive the forward transmission response are such that it is a function of the DUT's forward and reverse transmission and reflection parameters. So the network analyzer must make both a forward and reverse test sweep before it is able to calculate and update the transmission response.

Compared to ±0.15 dB, uncertainty of enhanced response calibration with attenuator, an Agilent 8720ES with two-port error correction for the filter example yields a total measurement uncertainty of ±0.13 dB. Also, since enhanced response calibration only requires a forward measurement, analyzer sweep time is half the sweep time required for a two-port calibration. These benefits make enhanced response calibration a suitable alternative for many applications.

Want more information on network analyzer calibrations? Ask for Application Note 1287-3, *Applying Error Correction to Network Analyzer Measurements*.

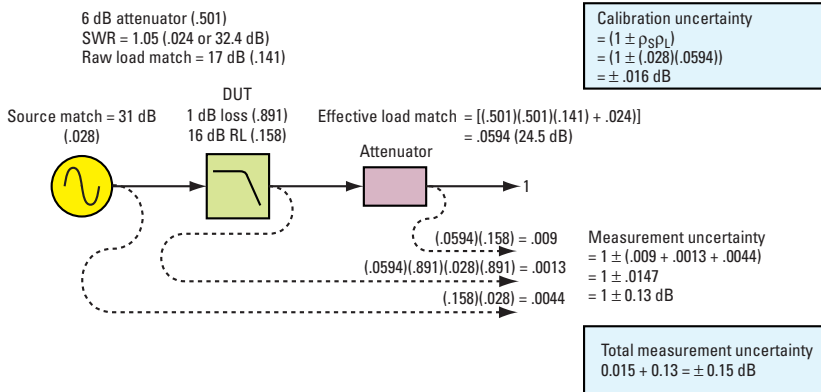

Figure 4. Using the enhanced response calibration plus an attenuator



Find us on the web

www.agilent.com/find/8510-8720news

Calendar of Events

Symposia and Trade Shows

- June 11 – 16 2000 IEEE MTT-S International Microwave Symposium and Exhibition.
Boston, Massachusetts, U.S.A.
- June 15 – 16 55th Automatic RF Techniques Group Congerence (ARFTG).
Boston, Massachusetts, U.S.A.
- August 21 – 25 IEEE International Symposium on Electromagnetic Compatibility.
Washington, DC, U.S.A.
- September 10 – 13 Radio and Wireless Conference (RAWCON 2000).
Denver, Colorado, U.S.A.

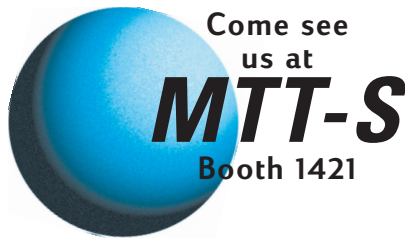

By internet, phone, or fax, get assistance with all your test and measurement needs

Online assistance:

www.agilent.com/find/assist

**Phone or Fax
United States:**
Agilent Technologies
(tel) 1 800 452 4844

Canada:
Agilent Technologies Canada Inc.
(tel) 1 877 894 4414

Europe:
Agilent Technologies
Test and Measurement
European Marketing Organisation
(tel) (31 20) 547 2000

Japan:
Agilent Technologies Japan Ltd.
(tel) (81) 426 56 7832
(fax) (81) 426 56 7840

Latin America:
Agilent Technologies
Latin American Region Headquarters
(tel) (305) 267 4245
(fax) (305) 267 4286

Australia/New Zealand:
Agilent Technologies Australia Pty Ltd
(tel) 1-800 629 485 (Australia)
(fax) (61 3) 9272 0749
(tel) 0 800 738 378 (New Zealand)
(fax) (64 4) 802 6881

Asia Pacific:
Agilent Technologies, Hong Kong
(tel) (852) 3197 7777
(fax) (852) 2506 9284

**Product specifications and descriptions
in this document subject to change
Copyright © 2000 Agilent Technologies
Printed in U.S.A. 5/00
5980-0390E**



Agilent Technologies

Innovating the HP Way

Agilent Technologies, Inc.
Dept. 8510NEWS400
P.O. Box 3828
Englewood, CO 80155-3828